

EVLL VERTICAL PACKAGING MACHINES



VERTICAL PACKAGING MACHINES

EVLL



Vertical packaging machines are designed for packaging solid, powdered, liquid, or pasty products in bags of different formats. Starting from a film reel, these machines form the bag, fill it and seal it in a single operation.

These packaging machines allow the use of both round and rectangular formers, with central vertical or side seals. The film is fed through a motorized belts' system. Additionally, they are equipped with a thermostating system by means of clamps that ensure the quality and tightness of the bag.

Depending on the nature of the product to be packaged, we offer different dosing systems: endless screw, volumetric metering units for powders or liquids, linear weighers, etc.

The EVLL packaging machines feature an electronic control by PLC or microprocessor (depending on the customer's needs) with touch screen that allows for data input, storage, and display.

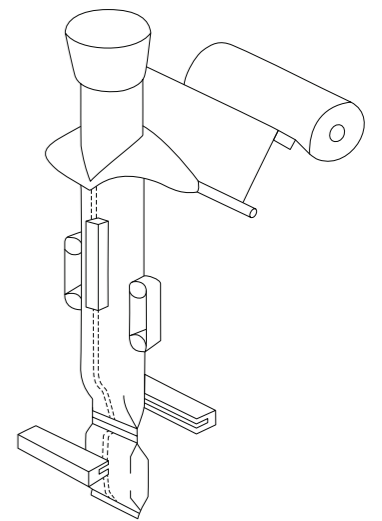

Forming tube



ADVANTAGES

- » Compact design.
- » They stand out for their high production speed.
- » Suitable for a wide variety of products, therefore, they are ideal for the pharmaceutical, cosmetics, food, and general chemical industries.
- » Quick and easy film reel change.

EVLL-260 Vertical packaging machines



with you, step by step

EVLL-160 PACKAGING MACHINE

The EVLL-160 model is designed to provide an efficient and simple packaging solution for those applications requiring low-budget equipment.

This equipment is suitable for packaging nuts, spices, legumes, rice, as well as detergents.

Technical specifications

Bag width	Min. 60 mm - max. 160 mm
Bag length	Min. 60 mm - max. 400 mm
Wrapping material	Polyethylene and complex
Drive system	Pneumatic
Film sheet drive	By pulleys
Blade type	Toothed (fine tooth, coarse tooth or special smooth cut)
Sealing type	Overlapped or returned
Control	Electronic with microprocessor
Electrical power	4 KVA
Air machine supply	25 L/min
Air welding supply	30 L/min
Production rate	Max. 50 bags/min. (depending on the bag type)*

*Mechanical cadence conditioned by the behaviour of the film, the product to be packaged, etc.



Bags

The EVLL-160 model can produce the following bag formats:



English fold bag

Pillow bag

Flat bottom bag

EVLL-260 PACKAGING MACHINE

The EVLL-260 is a small/medium format packaging machine, with high performance and great versatility, useful for packaging from a few grams to 2 or 3 kg of product, depending on its density.

This equipment is suitable for packaging nuts, coffee, tea, flour, sugar, etc. as well as detergents pet food or gypsum.

Technical specifications

Bag width	Min. 60 mm - max. 260 mm
Bag length	Min. 60 mm - max. 500 mm
Wrapping material	Polyethylene and complex
Drive system	Pneumatic (optional servomotors)
Film sheet drive	By pulleys (optional by vacuum)
Blade type	Toothed (fine tooth, coarse tooth or special smooth cut)
Sealing type	Overlapped or returned
Control	Electronic with microprocessor
Electrical power	4 KVA
Air machine supply	30 L/min
Air welding supply	40 L/min
Production rate	Max. 60 bags/min. (depending on the bag type)*

*Mechanical cadence conditioned by the behaviour of the film, the product to be packaged, etc.



Bags

The EVLL-260 model can perform the following bag formats:

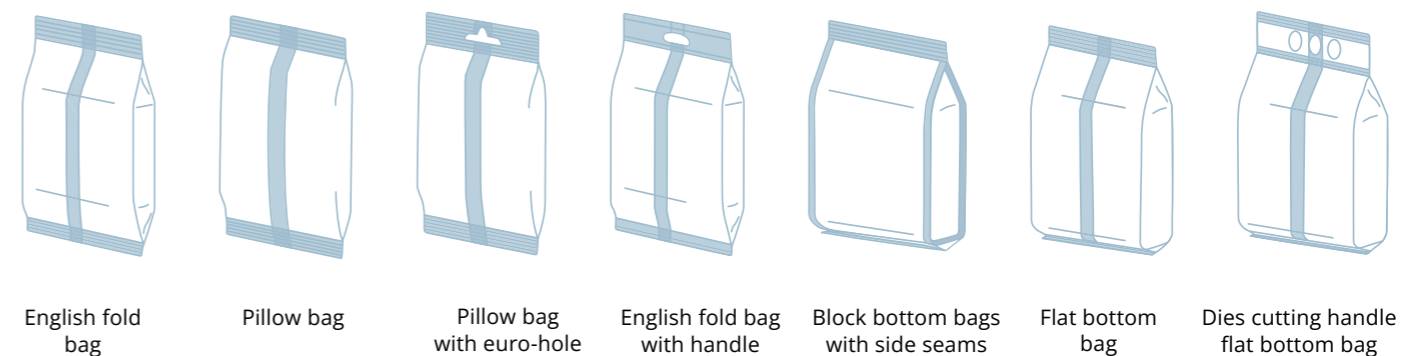

English fold bag

Pillow bag

Pillow bag with euro-hole

English fold bag with handle

Block bottom bags with side seams

Flat bottom bag

Dies cutting handle flat bottom bag

EVLL-400 PACKAGING MACHINE

The EVLL-400 model is designed for medium to large volume packaging without reaching the bulk format packaging. It allows packaging from 100 grams to between 2 - 10 kg of product, depending on its density.

This equipment is perfect for packaging frozen food, 4th range vegetables, pasta, rice, etc., as well as pet food, gypsum or phytosanitary products.

Technical specifications

Bag width	Min. 140 mm - max. 400 mm
Bag length	Min. 100 mm - max. 1,000 mm
Wrapping material	Polyethylene and complex
Drive system	Pneumatic (optional servomotors)
Film sheet drive	By pulleys (optional by vacuum)
Blade type	Toothed (fine tooth, coarse tooth or special smooth cut)
Sealing type	Overlapped or returned
Control	Electronic with microprocessor
Electrical power	5.5 KVA
Air machine supply	35 L/min
Air welding supply	50 L/min
Production rate	Max. 50 bags/min. (depending on the bag type)*



*Mechanical cadence conditioned by the behaviour of the film, the product to be packaged, etc.

Bags

The EVLL-400 model can produce the following bag formats:

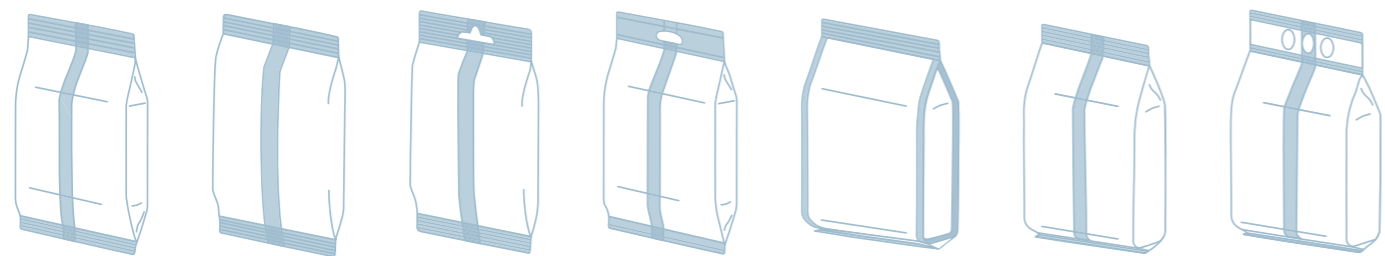

English fold bag Pillow bag Pillow bag with euro-hole Pillow bag with euro-hole Block bottom bags with side seams Flat bottom bag Dies cutting handle flat bottom bag

EVLL-600 PACKAGING MACHINE

This is a large-scale equipment, ideal for packaging in large formats: products that require high volume packaging due to their low density or high weight.

This equipment is perfect for the packaging of pet food, cement, additives, fertilizers, plastic pellets, detergent, etc.

Technical specifications

Bag width	Min. 200 mm - max. 600 mm
Bag length	Min. 100 mm - max. 1,000 mm
Wrapping material	Polyethylene and complex
Drive system	Pneumatic (optional servomotors)
Film sheet drive	By pulleys (optional by vacuum)
Blade type	Toothed (fine tooth, coarse tooth or special smooth cut)
Sealing type	Overlapped or returned
Control	Electronic with microprocessor
Electrical power	6 KVA
Air machine supply	40 L/min
Air welding supply	60 L/min
Production rate	Max. 20 bags/min. (depending on the bag type)*

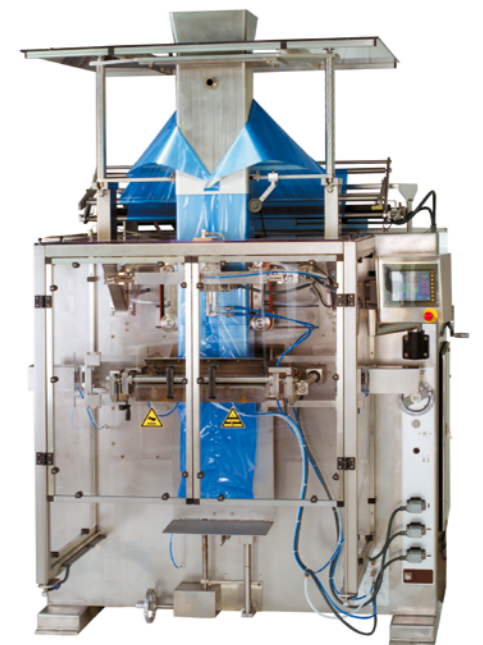

*Mechanical cadence conditioned by the behaviour of the film, the product to be packaged, etc.

Bags

The EVLL-260 model can perform the following bag formats:

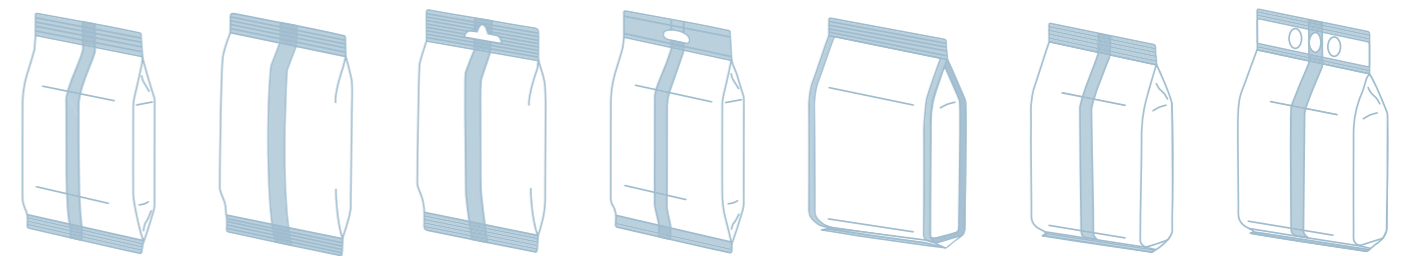

English fold bag Pillow bag Pillow bag with euro-hole English fold bag with handle Block bottom bags with side seams Flat bottom bag Dies cutting handle flat bottom bag

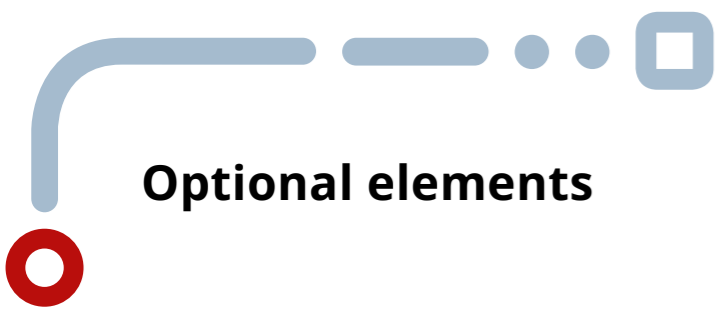

Optional elements

Vertical packaging machines can be equipped with different systems to adapt to different types of products, environments, and specific needs.

OPTIONS	Models			
	EVLL-160	EVLL-260	EVLL- 400	EVLL-600
Stainless steel construction	✓	✓	✓	✓
Servomotor drive	—	✓	✓	✓
Automatic reel correction	—	✓	✓	✓
Vacuum dragging	—	✓	✓	✓
Static discharge unit	✓	✓	✓	✓
Bottom vibrator	✓	✓	✓	✓
Inert gas injection	✓	✓	✓	✓
Reel splicer	—	✓	✓	✓
Suction	✓	✓	✓	✓
Printing equipment	✓	✓	✓	✓



Available dosing systems



Depending on the nature of the product to be packaged, we have different dosing systems.

DPLL POWDER DOSING UNITS

The DPLL dosing unit is specially designed for the dosing of powdery products. It stands out for its reliability, speed, and easy cleaning. The dosing is carried out using a vertical screw conveyor, with a diameter that can be selected base on the product to be packaged, and the dosing control is carried out by weight. This equipment is easily adaptable to the different vertical packaging machines available.



EVLL-160 vertical packaging machine fed by a DPLL-1/5 dosing unit and a screw conveyor.

LINEAR SOLID WEIGHERS MACHINES

Linear weighers are precision equipment capable of dosing a wide variety of solid products thanks to their special design for each application.

They are particularly suitable for the dosing of candies, sweets, coffee beans, tea, pasta, nuts, olives, potatoes, rice, sugar, salt, etc.

Each of the heads is composed of:



Linear product

- » Product reception hopper equipped with a vibrating paddle to feed the product conveying channels.
- » Division of the product into two different flow rates, "Pre-dosage" and "Fine-tuning" by means of two independent and parallel vibrating channels.
- » Weighing bowl, controlled by weight cell and operated by pneumatic opening.

The weighers can be installed on other packaging equipment such as thermoforming units or thermosealing, among others, unloading on different trays simultaneously. Additionally, by installing an inlet and an outlet, a weighing equipment can be used to weigh product in large quantities and discharge it into boxes.



Linear weigher assembled on EVLL packaging machine



Linear weigher ready to be installed on a thermoforming unit or belt conveyor

Available dosing systems

MULTIHEAD WEIGHERS

Multihead weighers are high-speed and high-precision weighing equipment working by means of combinatorial weighing.

They are widely used for dosing of candies, snacks, nuts, sweets, fruits, and other vegetables, frozen food, and pet food.

- » Number of weighing vessels: 10, 12, 14, 16, 16/32.
- » Vessel size between 2 and 10 litres.
- » Material of construction: stainless steel for parts in contact with the product.



Multihead weigher

VOLUMETRIC DOSING UNIT FOR SOLIDS

The volumetric dosing unit is an equipment specially designed for packing products of uniform granulometry at a high throughput rate and with a significantly lower investment compared to a weighing equipment of similar characteristics.

It has interchangeable stainless steel telescopic cups with capacity adjustment in the ratio of 1 to 2.

These dosing units are widely used with products such as rice, legumes, nuts, sugar, salt, detergent, and other uniform granules.



Volumetric dosing unit for solids



DOSIFIX LIQUID DOSING UNIT

The DOSIFIX is the ideal equipment for dosing liquid and viscous products. Thanks to its easy-to-clean design, this equipment can be implemented in the pharmaceutical, cosmetic, food, and chemical industries: ointments, creams, body milks, sauces, detergents, colourants, etc.

Dosing is carried out by means of a pneumatically operated piston or plunger with adjustable speed, which allows it to adapt to any viscosity.

- » Throughput: 400 - 1,200 containers per hour depending on dosage.
- » Dosing range DN-300 model: 8 - 80 cm³, 10 - 200 cm³ and 15 - 300 cm³
- » Dosing range DN-1000 model: 15 - 300 cm³ and 50 - 1,000 cm³.



DN-300 DOSIFIX with 25-litre feed hopper

MINOX LIQUID DOSING UNIT

The MINOX is mainly indicated for dosing food, cosmetic, and pharmaceutical products, due to all parts of the equipment are made of stainless steel. It allows the economical dosing of low and medium viscosity liquid products.

The MINOX filling machines works on the same principle as a reciprocating pump. A specific amount of product is displaced in each stroke of the machine. The machine is equipped with a 3-way valve, a dosing cylinder, a plunger, a hopper, and the corresponding pneumatic drive mechanism.

- » Throughput: 30 strokes/minute.
- » Dosing range: variable from 10 to 250 cm³.



MINOX dosing machine